

Hot Stamp Text
P/N CP7018R
Color Orange

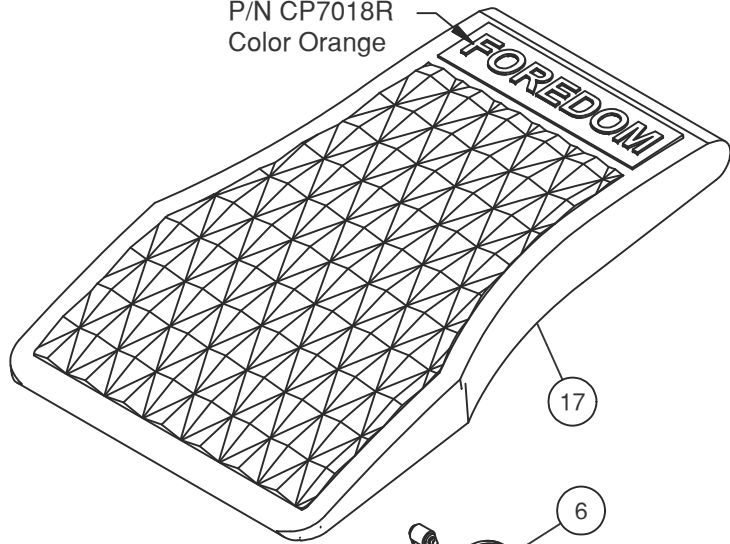

Female Receptacle
to Motor CP10868

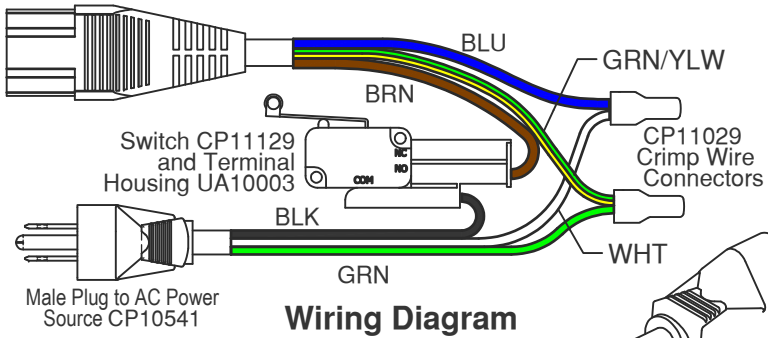

Parts List

C.FCG-2 ON/OFF Foot Switch

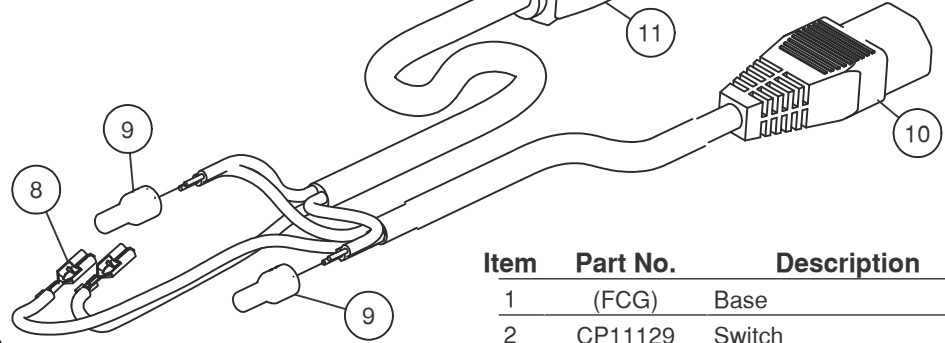
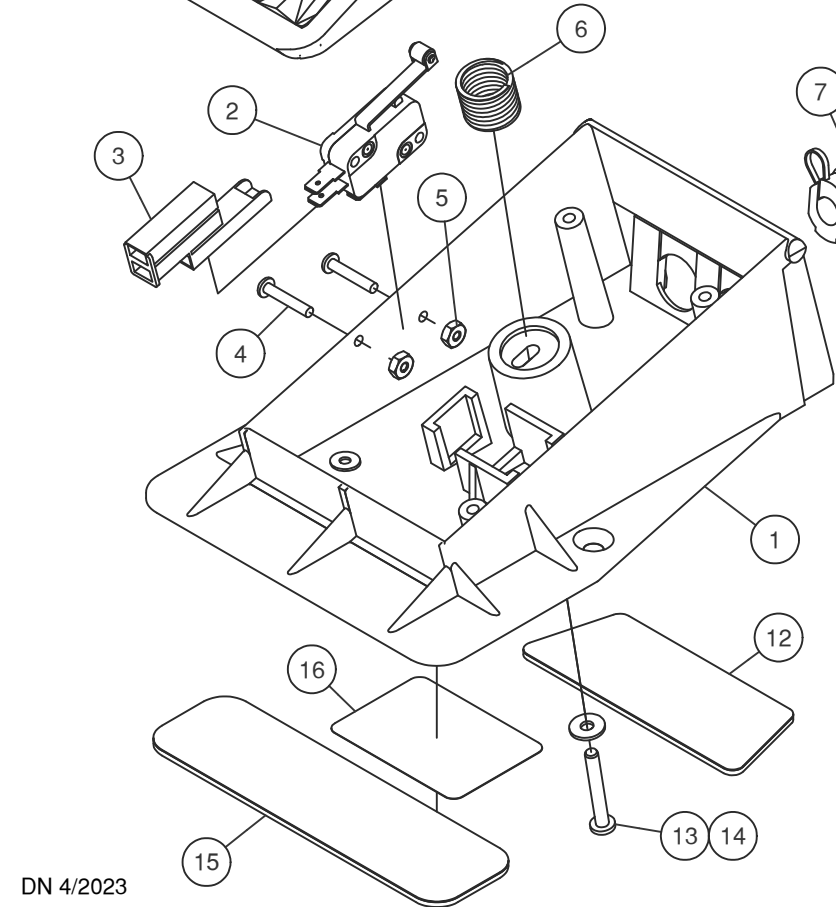

Item	Part No.	Description	Qty
1	(FCG)	Base	1
2	CP11129	Switch	1
3	UA10003	Faston Terminal Housing	1
4	CP11157	Screw, 4-40 x 5/8	2
5	CP11132	Nut, 4-40	2
6	CP10861	Spring	1
7	CP10003-3	Strain Relief	2
8	UA10004	Female Connector	2
9	CP11029	Crimp-On Connector	2
10	CP10868	Female Cordset	1
11	CP10541	Male Cordset	1
12	CP10860	Foot Pad, Rear	1
13	CP10856	Screw, 6-32 x 1"	1
14	CP10862	Washer, #6	1
15	CP10859	Foot Pad, Front	1
16	C.FCG-2.LAB	Specification Label	1
17	CP10852	Cover	1