

2

1

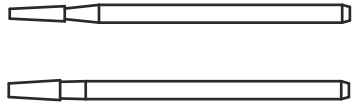

PART NO.	SIZE	ØDIM. A	ØDIM. B	DIM. C	ØDIM. D	DIM. E
A-PD14	1.9 mm	1.90	1.30	7.00	1.40	4.5
A-PD15	2.6 mm	2.60	1.80	7.00	1.80	3.4

ABRASIVE TYPE NATURAL DIAMOND
 GRIT SIZE MEDIUM
 BONDING TYPE METAL, SINTERED

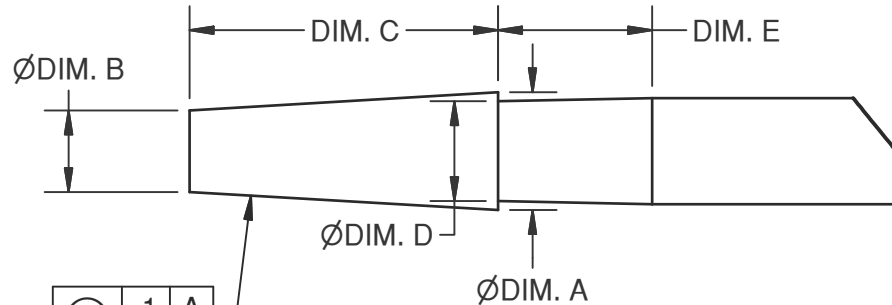

DETAIL A
SCALE 6

	.1	A
	.002	A

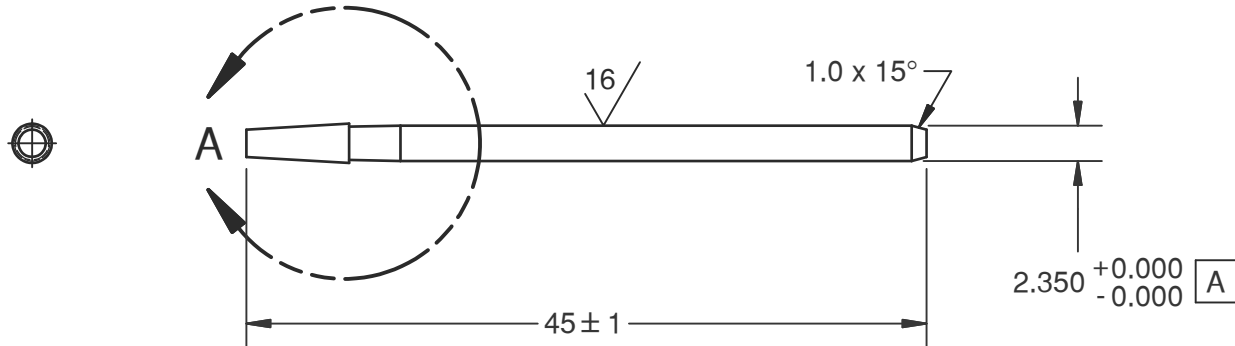

NOTICE

This drawing may represent a proprietary article or one on which patents are applied for or issued. Reproduction thereof or manufacture of parts therefrom is not permissible without the written permission of Blackstone Ind., Bethel Conn. 06801, or its subsidiaries.

UNLESS OTHERWISE SPECIFIED DIMENSIONS ARE IN MILLIMETERS TOLERANCES ON: 1 PL DEC. ± 0.25 2 PL DEC. ± 0.13 ANGLES ± 2°	SIGNATURES	DATE	Blackstone Industries, Inc. Bethel, Connecticut 06801	
	DRAWN D.N.	10/25/2010		
	CHECKED		PART NAME	
	APPROVED		DIAMOND POINT, TAPER, Ø2.35mm SHANK	
MATERIAL- STAINLESS STEEL 430 F	PART NO.	SEE TABLE	SCALE 2 TO 1	
	DWG. NO.	08A01093	REV.	

2

1