

Parts List

C.SCH-2* & C.SCT-2 Foot Control, 230V

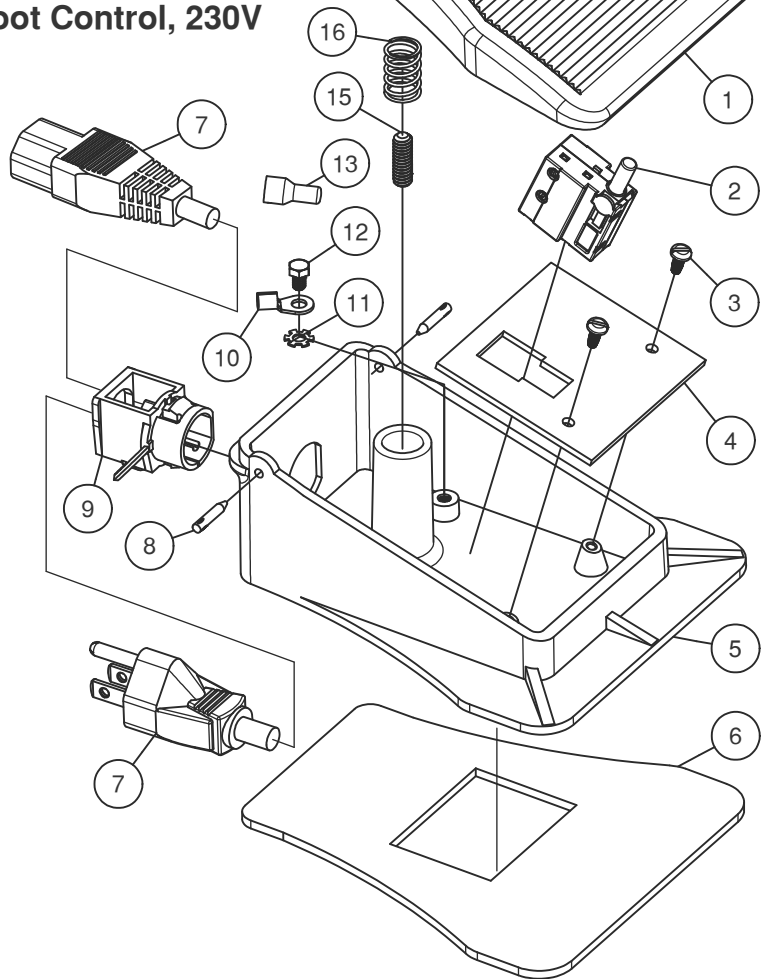

Instructions for Removing and Replacing Trigger Switch

Disconnect Foot Control from Motor and Wall Outlet.

1. With a punch and hammer drive two Pins (8) in until Cover (1) lifts from each side of Base (5).
2. Remove Cover and drive Pins outward with hammer and punch to remove.
3. Remove two Screws (3) from Bracket (4). After the wires have been removed from the switch, as instructed in paragraph 4, remove the switch from the board, insert the new switch in its place, and follow the instructions in paragraph 5 and 6.
4. On older Switches, all the terminals will be push-in, spring clamp type. On newer Switches, Terminal 1 has a screw for fastening the wire lead. To remove wires from the push-in terminals, insert 1.3mm [.05in] approximate diameter pin or the blade of a jeweler's screwdriver all the way into the terminal socket to release the spring clamp. Grasp the tool and wire and pull them together out of the socket. If you have difficulty removing the wires from the push-in terminals and you have wire-cutting, stripping, and soldering tools, you can cut the wires off where they exit from the terminals. To prepare the cut wires for installation into the replacement Switch, strip them back exactly 8.25 mm [5/16 in], then apply solder to the stripped ends to fuse the strands together.
5. Insert new Trigger Switch into Bracket.
6. **Connect Wires to New Trigger Switch as shown in the Wiring Diagram.** Push wires all the way in, so that no bare wire is exposed. On Screw Terminal 1, push the wire lead all the way into the socket then tighten the screw firmly. Push the other wire lead all the way into terminal 6. Pull on all the wires, making sure they are secure.
7. Install Bracket and Switch into Base using two Screws (3).
8. Position wires around post of Base so wires will not interfere with Cover travel.
9. Install Cover over Spring (16) and align holes to Base. Insert Pins (8) and seat them with hammer.

Item	Part No.	Description	Qty
1	CP10691	Cover	1
2	CP11027	Trigger Switch, 250V	1
3	CP10571	Screw, 6-32 x 5/16"	2
4	CP11030	Bracket	1
5	CP10690	Base	1
6	CP10753	Base Pad	1
7	CP10541	Male Cordset or Substitute Option	1
8	CP10584C	Hinge Pin	2
9	CP10578	Grommet	1
10	CP10580	Terminal Ring	1
11	CP10564	Lock Washer, #8	1
12	CP10563	Screw, 8-32 x 1/4"	1
13	CP11029	Wire Connector	1
14	CP10542	Female Cordset (SCT-2)	1
	CP10868	Female Cordset (SCH-2)	
15	CP10562	Set Screw	1
16	CP10588	Spring	1

Cordset Option	Part No.	Description
CPOption20	CP10545	No Plug, Europe
CPOption21	CP10553	Male, United Kingdom
CPOption22	CP10554	Male, Continental Europe
CPOption25	CP10555	Male India 10A
CPOption26	CP10556	Male, Australia

Wiring Diagram

*C.SCH-2 is required for use with the latest SR 230V Motors produced since May 2006.

