

Parts List

C.FCT-1 and C.FCH-1
Foot Control, 115V

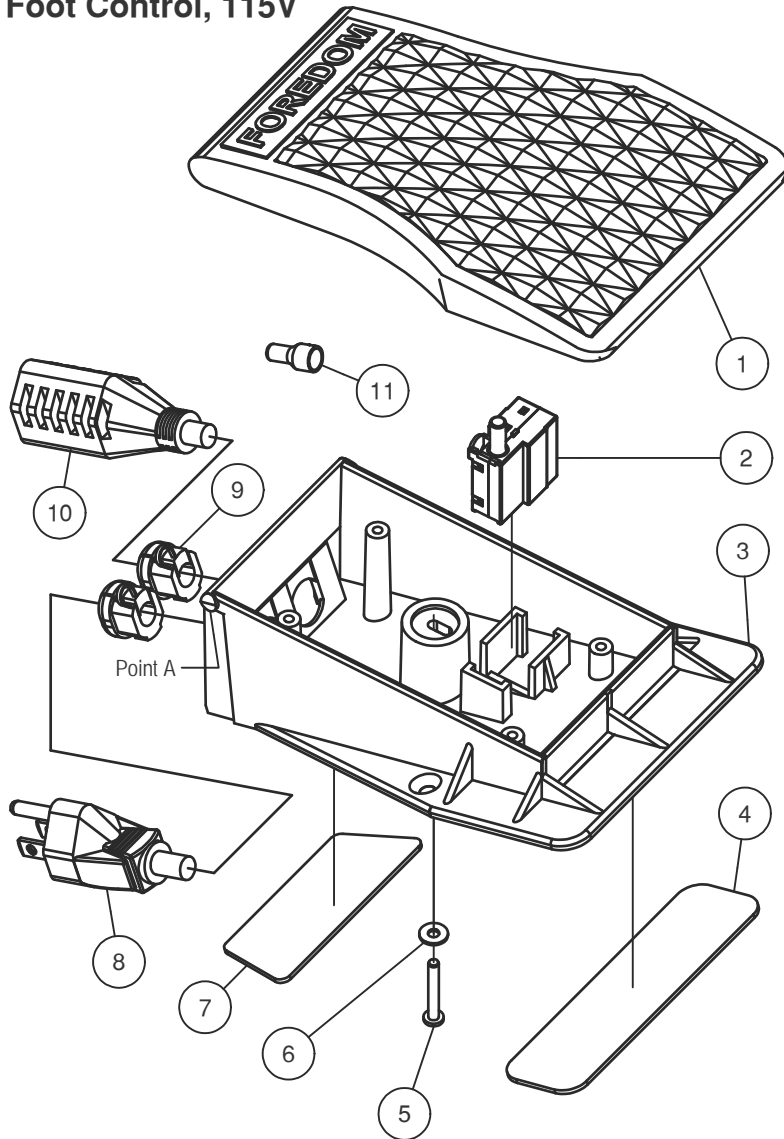

Instructions for Removing and Replacing Trigger Switch

Disconnect Foot Control from Motor and Wall Outlet.

1. Unscrew cover adjustment screw (5).
2. Using flat blade of screwdriver inserted at Point A between Cover (1) and Base (3), carefully pry Cover off.
3. Remove Trigger Switch (2) from Base mounting bracket.
4. On older Switches, all the terminals will be push-in, spring clamp type. On newer Switches, some terminals have screw fasteners. To remove wires from the push-in terminals, insert 1.3mm [.05in] approximate diameter pin or the blade of a jeweler's screwdriver all the way into the terminal socket to release the spring clamp. Grasp the tool and wire and pull them together out of the socket. If you have difficulty removing the wires from the push-in terminals and you have wire-cutting, stripping, and soldering tools, you can cut the wires off where they exit from the terminals. To prepare the cut wires for installation into the replacement Switch, strip them back exactly 8.25 mm [5/16 in], then apply solder to the stripped ends to fuse the strands together.
5. **Connect Wires to New Trigger Switch as shown in the Wiring Diagram.** Push wires all the way in, so no bare wire is exposed. On Screw Terminal 1, push wire lead all the way into the socket then tighten the screw firmly. Push other wire leads all the way into the designated terminals. Pull on all the wires, making sure they are secure. Place Switch back into Base mounting bracket.
6. Position wires around adjustment screw post so wires will not interfere with cover travel.
7. Snap cover (1) onto hinge posts on top of rear corners of base (3).
8. Insert adjustment screw (5) through washer (6) and into post slot and threaded insert in cover (1). Tighten with screwdriver until cover is just touching the trigger switch pushrod. **Do not tighten the screw further** to avoid pressing the Switch Pushrod into a permanently "on" position.

Wiring Diagram

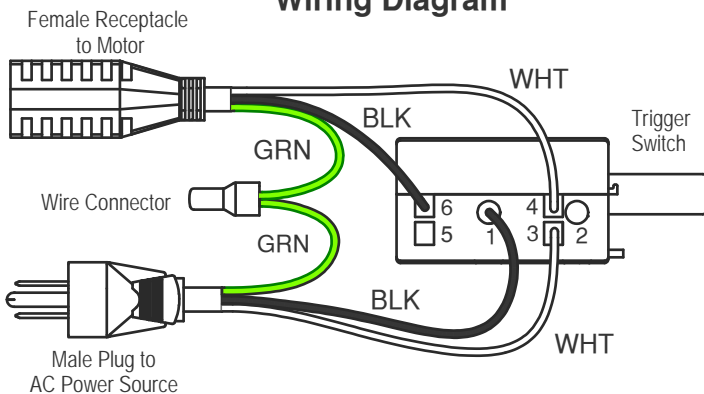

Item	Part No.	Description	Qty
1	CP10852A	Cover	1
2	CP10857	Trigger Switch, 125V	1
3	CP10851	Base	1
4	CP10859	Front Base Pad	1
5	CP10856	Screw, 6-32 x 1"	1
6	CP10862	Washer, #6	1
7	CP10860	Rear Base Pad	1
8	CP10541	Male Cordset	1
9	CP10003-3	Strain Relief	2
10	CP10542	Female Cordset (FCT-1)	1
	CP10830	Female Cordset (FCH-1)	
11	CP11029	Wire Connector	1

FOREDOM® The Foredom Electric Company

16 Stony Hill Rd., Bethel, CT 06801 • 203-792-8622

Fax: 203-796-7861 • www.foredom.net

Form DN 12/10