



Owner's Manual for 1/6 HP Series SR Flexible Shaft Power Tools

**See Insert with
Special Instructions
for Heavy Duty
Series SRH Models**

For Your Own Safety

- Please read this Assembly, Operation, and Service Manual before operating your Foredom power tool.
- Always wear eye protection while using power tools.
- Only use accessories rated for use at 18,000 RPM.

FOREDOM[®]

www.foredom.net

Contents	Page
Safety Instructions	2–4
Series SR Motors and Speed Controls	4-7
Assembly Instructions	5–6
Assembly and Adjustment of Shaft, Sheath & Handpiece	5
Connecting Foot Controls	6
Connecting Table-Top Dial Speed Controls	6
Operation – General Guidelines	7
Foredom Handpieces and Rotary Accessories	8–10
Attaching Accessories to Handpieces	9
Handpiece Lubrication	10
General Accessory Recommendations	11–12
Maintenance Procedures	13–14
Routine Motor Cleaning and Lubrication	13
Replacement of Worn Shafts and Sheaths	14
Replacement of Motor Brushes	14
Repair Service	15
Recommended Spare Parts and Supplies	15
Motor Hangers	15
Limited Warranty	16
Contact Information	16

How-To Videos on www.foredom.net

Click on our homepage link where Foredom's National Sales Manager shows you the basics of using and maintaining flexible shaft machines.

Click to View:

- 1. Intro & Proper Set-up**
- 2. Safety Guidelines**
- 3. Handpieces & Accessories**
- 4. Shaft and Sheath Maintenance – Grease and Replace**
- 5. Motor Maintenance– Remove Dust, Replace Motor Brushes**

We have other product-related videos embedded throughout our website. We suggest that you take the time to watch these since they help to clarify product features, differences, and uses.

Visit Foredom on www.youtube.com

Safety Instructions

Before using your Foredom power tool, please read safety instructions. They are for your protection and should always be followed to reduce the risk of personal injury or damage to the tool.

- **Always wear proper eye and face protection.** Wear safety glasses or face shields whenever you operate a Foredom or any power tool to prevent serious eye or face injuries.
- **Secure the work piece or item that you are working on** in a vise or other work holding device. Holding it with your hand can result in serious hand injury.
- **Always use a proper dust collection system or wear a respirator** to prevent the inhalation of dust particles, polishing compounds, or other debris into the lungs.
- **Do not wear loose fitting clothing or jewelry.** Loose clothing or jewelry can become entangled in the rotating accessory. Do not

wear items such as neckties, necklaces, or bracelets when operating power tools. Be sure to **tie back or secure long hair.**

- **Secure power tool to motor hanger or work surface.** Flexible shaft power tools can “jump” at start up or vibrate during operation. The tool should be properly secured in order to prevent it from vibrating off of the motor hanger or work bench.
- **Never operate any accessory at speeds above its maximum rated speed.** When properly used, all of Foredom's accessories can be operated at the speed ratings listed in the Foredom Accessory Catalog or specified on kits and packages. **Always** find out the manufacturer's speed rating before using accessories other than those from Foredom.
- **For added safety and comfort** while using this power tool for carving or other applications, it is recommended that you wear a

heavy canvas or leather apron. It will protect you from dust, debris and chips as well as help prevent injury if the handpiece slips off the workpiece. It will also help prevent loose clothing from getting caught in a rotating cutter, bur or other accessory.

- **Never use or continue to use any accessory which appears to be damaged, loose, vibrating, or out of balance.** Inspect each accessory for cracks or flaws before using it. Avoid knots, imperfections in the wood or metal objects like nails, which could damage or catch the accessory.
- **Always** insert the shank or arbor of an accessory or mandrel into the collet or chuck of the handpiece as far as possible in order to provide proper support and tighten the collet or chuck securely.
- **Never** use excessive side pressure which may bend or break the shank or arbor of an accessory. Let the speed of the accessory do the work.
- **Do not** stall the motor by jamming or using excessive pressure on the accessory. This can result in damage to the motor or flexible shaft.
- **Never operate the motor with the outer sheath removed from the flexible shaft.**

- **Always disconnect** the power cord before servicing the motor or removing the flexible shaft or sheath.
- **Never** operate your power tool during a perceptible power decrease. Turn power tool off and do not use until power is fully restored.
- **Use proper grounding procedures.** This tool should be grounded while in use to protect the operator from electric shock. The tool is equipped with an approved 3-conductor cord and a 3-prong grounding type plug to fit the proper grounding receptacle. The green (or green and yellow) conductor in the cord is the grounding wire. Never connect the green (or green and yellow) wire to a live terminal. If your unit is for use on less than 150 volts, it has a plug that looks like sketch A below. An adapter (sketches B and C) can be used for connecting plugs as shown in sketch A to 2-prong receptacles. The green colored rigid ear, lug, etc., extending from the adapter must be connected to a permanent ground such as a properly grounded outlet box. **Some jurisdictions, including Canada, prohibit the use of 3 to 2 prong adapters. Where prohibited, they should not be used.** Use only 3-wire extension cords that have 3-prong grounding type plugs and 3-pole type plugs and 3-pole receptacles that accept the tool's plug. Always disconnect the power cord before servicing the tool. Never use in an area where flammable vapors are present.

Replace or repair worn cord immediately.

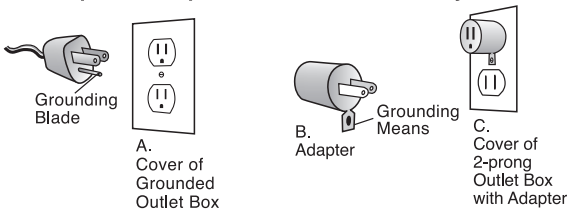

Never change motor direction while the motor is running.

Changing direction while motor is running can damage the motor or flexible shaft or lead to premature wear. To turn motor off, remove foot from foot pedal speed control, or turn dial speed control to "off" position, and set rocker switch to "off" (center) position on motor.

Never change motor direction while the motor is running.

OFF– no rotation.

FORWARD – counterclockwise shaft rotation.

Forward is going to be the most commonly used setting. Right-handed people will get the most control in the forward direction.

Forward Motor Rotation

- **ONLY use Chisel or Hammer handpieces or Angle Grinder attachment for H.30® handpiece in Forward Rotation. Using Chisel or Hammer handpieces or Angle Grinder attachment in reverse can damage the handpiece, attachment, flexible shaft, or motor and may cause injury.**
- **Use the forward motor direction ONLY for fluted burs, drills and cutters.** Most will cut efficiently **only** when turning in this direction.
- **Many mandrels have right-hand threaded arbor screws which will unscrew in the reverse direction.**
- **Dust and debris** flies away from the user when operated in **forward** in the **left hand**.



REVERSE – clockwise shaft rotation.

Advantages of Reverse Rotation

- Left-handed users will have better control in the reverse direction.
 - For **right** handed use, dust and debris flies away in **reverse**.
 - Alternating motor direction helps to extend the life of mounted abrasive points, buffs, brushes, sanding bands, and Typhoon® burs.
 - Reverse helps with accomplishing symmetrical grinding and carving techniques.
 - Reverse is good for “backing out” stuck drill bits and extending the life of sanding bands and abrasive accessories.
 - Alternating motor direction makes it easier and faster to polish metals.
 - Be sure to use a mandrel with a left-hand threaded arbor screw.
-
- Whether you are right or left handed or operate in forward or reverse, **precautions taken against dust and debris are always necessary and important.**
 - **Always securely tighten chuck nut or chuck jaws of handpiece with wrench or chuck key so that it will not come loose in the reverse or forward operating directions.**
- **Be sure to insert the shank of the accessory as far as possible into the collet or chuck to give it maximum support.**
 - **Always wear proper eye and face protection.** Wear safety glasses or face shields whenever you operate a Foredom or any power tool to prevent serious eye or face injuries.

Freedom® 1/6 HP Series SR Power Tools

You have purchased a fine quality power tool which will perform a wide variety of tasks difficult to do with any other kind of power tool. Freedom power tools are manufactured to high standards of precision and performance and with proper use and regular maintenance will give you years of trouble-free performance. This manual contains instructions for the assembly, operation, and servicing of Freedom's 1/6 hp Series SR motors.



M.SR Hang-Up Style



M.SRB Bench Style



M.SRM Bench Style
with built-in control

Your Series SR flexible shaft power tool consists of a motor, flexible shaft and sheath, speed control (foot or manual) and a handpiece. Locate and identify all components, parts and accessories you purchased before discarding the packing list and packing materials that came with your power tool.

Assembly Instructions

Always make sure your power tool is unplugged during assembly!

After identifying all the components of your power tool, assemble it in the following manner:

Assembly and Adjustment of Flexible Inner Shaft, Outer Sheath, & Handpiece

Proper assembly and adjustment of the flexible shaft and sheath are critical for the correct operation of your Freedom power tool.

The exposed tip (handpiece end) of the flexible shaft (with handpiece removed) must extend 3/4" (19mm) beyond the sheath.



Important Note: The shaft and sheath should be checked and adjusted (if necessary) even if you received them assembled and attached to the motor!

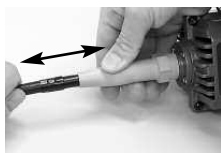
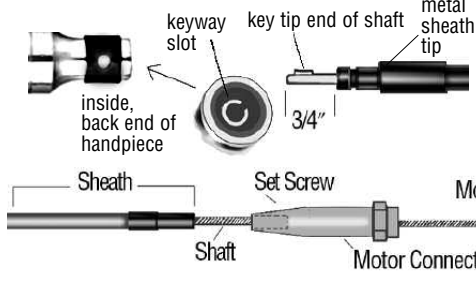

Please follow these directions to assemble and adjust the shaft and sheath.



To check the shaft and sheath you must first remove the handpiece.

The handpiece is easy to remove from the flexible shaft.

To remove:

1. First make sure your power tool is unplugged. Simply pull the handpiece off the shaft and sheath with a firm grip. **To Re-attach Handpiece:** while holding the black colored metal outer sheath tip facing upward, turn on the motor so that it is running at about half speed and then turn it off. While the inner key tip is still rotating, grip the handpiece and push it onto the sheath tip with one firm motion until it snaps into place (shown below). This procedure will align the key tip into the keyway slot (as shown below at left). To verify this, insert and tighten an accessory into collet or chuck, turn on control to low speed and observe that the accessory rotates smoothly.



2. With the handpiece removed, place the entire unit on a flat surface with the shaft and sheath extended straight. Loosen the set screw on the motor connector. **Adjust the exposed tip (handpiece end) of the flexible shaft so that it extends 3/4" (19mm) beyond the sheath,** as shown at left. This is done by moving the sheath in or out of the motor connector (motor end) as shown at left.

3. When the correct adjustment is made, re-tighten the set screw in the motor connector and re-attach handpiece onto the flexible shaft.

Be sure to follow the grounding instructions on page 3 of this manual while attaching the speed control to a power outlet.

Wait for motor to stop rotating before switching between forward or reverse.

To turn motor off, remove foot from foot pedal speed control, or turn dial speed control to "off" position, and set rocker switch to "off" (center) position on motor.



Connecting the Foot Speed Control

The electrical specifications for your power tool are listed on the label on back of motor. It shows proper voltage and currents to use with your power tool.

A 115 Volt, 50/60 cycle (Hz) motor can be used with the models C.FCT-1 and C.SCT-1 foot controls on 115 Volt **AC current only**. The 230 Volt, 50/60 cycle (Hz) motor can be used with the models C.FCH-2 and C.SCH-2 foot controls on 230 Volt **AC current only**.

To connect the foot control to the motor, insert the 3-prong plug on the end of the motor power cord into the socket connector on the shorter power cord on the foot control. **With the motor fwd/off/rev switch in the "off" position**, plug the 3-prong plug on the longer power cord from the foot control into a proper 3-prong power outlet.

When your foot is not pressing the foot control, the motor should not be running.

Your foot must maintain steady contact with the pedal during operation. Holding the handpiece in your hand, put the motor fwd/off/rev switch in the desired "on" position, begin with a light touch, start out slowly and gradually increase the speed. Finding the right speed for any specific task is a matter of experimentation and experience.



Hold the handpiece securely before selecting the rotation direction and turning the motor to the desired "on" position.

Hanging Motor Installation

M.SR Motors should be hung up about 30"-40" above the work surface and to the right of the work if you are right handed or to the left of the work if you are left handed.



Use a safety clip or hook like the one shown to prevent the motor from jumping or twisting off an open hook at start up or during use. Properly securing the motor will help to prevent injury to the user.

All Freedom motor hangers have this type of safety clip (see page 15). If an "open hook" is used be sure to secure the motor to it with wire or heavy tape.

Connecting the Table-Top Dial Speed Control

The motors can also be used with the C.EM-1 (115 volt) or C.EMH-2 (230 Volt) dial speed control on AC current. Connect the control to the motor by inserting the 3-prong plug on the end of the motor power cord into the socket connector on the shorter power cord on the dial control. With motor fwd/off/rev switch in the "off" position and the dial indicator arrow also in the "off" position on the control, plug the 3-prong plug on the longer power cord from the dial control into a proper 3-wire outlet (see page 3). Holding the handpiece in your hand, put the motor fwd/off/rev switch in the desired "on" position, begin with a light touch, start out slowly and gradually increase the speed. Finding the right speed for any specific task is a matter of experimentation and experience.

Operation – General Guidelines

Read all the safety instructions in this manual before operating your Foredom® Power Tool. Proper eye and face protection must be worn to protect you from injuries caused by flying debris, chips, or sparks which might result from the work being done.

It is possible to use rotary or chisel handpieces not made by Foredom with your Foredom flexible shaft power tool. However, this is not recommended since their function and safety cannot be assured by Foredom.

Your Foredom motor may be operated in a vertical or horizontal position, but it should *not* be enclosed or confined so as to restrict air circulation. If the motor is hung up above a workbench, be sure it is fastened securely to the wall or motor hanger. The motor may develop a high operating temperature (up to 100°F + ambient) after prolonged use, and it will be too hot to hold. This will not harm the motor which is designed to operate at this temperature for prolonged periods.

Do not force the tool

Let the speed of the tool do the work. Avoid using too much pressure. Generally, slower speeds are used for rougher, heavier work or when greater control over the accessory is required for precise, delicate work. Higher speeds are used for buffing, cutting and polishing. Read Accessory Recommendations on pages 11 and 12 of this manual.

Voltage Decreases

Never operate a power tool during a perceptible power decrease. Turn off tool and unplug until full power is restored.

Always wear proper eye and face protection when operating a Foredom power tool.

Wait for motor to stop rotating before switching between forward or reverse.

To turn motor off, remove foot from foot pedal speed control, or turn dial speed control to “off” position, and set rocker switch to “off” (center) position on motor.

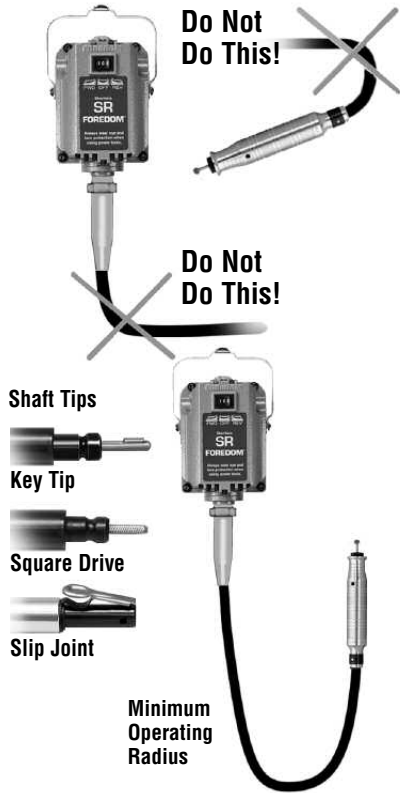

Do not bend shaft and sheath at tight angle

When operating your Foredom tool **be careful not to bend the flexible shaft too much at either the handpiece or motor shaft connections.** Shafts and sheaths last longer when they are used without sharp bends. If used at angles or loops, wear will occur at the points of greatest friction. Excessive heat and wear will occur if the bend is too great.

Torsional Breaking Point:

Key Tip (Standard) Shaft	24-lbs.-in.
Square Drive (Heavy Duty) Shaft	50-lbs.-in.
Slip Joint (European) Shaft	24-lbs.-in.

Follow these guidelines for trouble-free use:

a 4" or larger radius, as shown, should be maintained for shafts on all motors. There is no way to avoid ultimate wear and under normal conditions a flexible shaft machine may require several replacement shafts and sheaths during its lifetime. (Follow shaft and sheath assembly instruction in the Assembly section of this manual.)

FOREDOM® Handpieces (burs not included)



H.8



H.8D



H.10



H.10D



H.15



H.15D



H.18



H.18D



H.20



H.20D

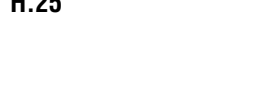

H.25



H.28

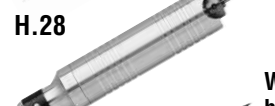

H.30®



H.35



H.43T



H.44T



H.50



H.52



H.52D

With the H.35 handpiece use only accessories rated for 35,000 RPM or higher.

Never run Handpieces H.15, H.15D or H.50 in reverse rotation.

See insert for special square drive handpieces for use with Series SRH motors.

Attaching Accessories to Handpieces

Directions for attaching accessories to handpieces vary according to the type of handpiece being used. Locate the model number of your Foredom handpiece from the photos on page 8. **Always wait for the motor, flexible shaft and accessory to come to a complete stop before changing an accessory.**

(Handpieces listed in brackets are for use with Series SRH models only.) Attach the accessory according to the following:

Collet Types –

8, 8D, 25, (25H), 28, 28SJ, (28H), 35, 35SJ, 43T, 44T, 44TSJ, & (44HT) Handpieces:

A collet is an interchangeable slotted cylinder inserted tightly into the interior of a handpiece to hold a bur or other rotary accessory. The diameter size of the collet must match the diameter of the accessory's shank.

General Directions: Be sure to use the correct shank size. The correct shank will fit snugly inside the collet. **Caution: Never tighten a collet unless an accessory has been inserted.** Tightening an empty collet or inserting an accessory which is too small or too large may damage the collet.

8, 8D, and 8SJ Handpieces:

To change a collet: slide back the chuck guard and use one wrench to hold the spindle and the other to unscrew the chuck nut by turning counterclockwise. Remove chuck nut to expose collet and pull collet out of handpiece shaft. Slip new collet in place and tighten chuck nut with wrenches.

To insert accessory: insert shank as far as possible into the collet. Tighten chuck nut. Test for a secure hold by pulling on accessory. Remove wrenches. To release an accessory, follow the same steps. Accessories can be released when chuck nut is loosened. If accessory does not run true, loosen chuck nut, rotate accessory, and retighten.

25, (25H), 28, 28SJ, (28H), 35, 35SJ, 43T, 44T, 44TSJ & (44HT) Handpieces:

To change a collet: 1. Insert pin provided into the pilot hole and through the spindle hole (turn spindle to align holes). Apply wrench and unscrew chuck nut by turning counterclockwise.

2. Remove chuck nut to expose collet.

3. Pull collet out of handpiece spindle.

4. Slip new collet in place and screw on chuck nut.

5. Remove pin.



25, (25H), 28, 28SJ, (28H), 35, 35SJ, 43T, 44T, (44HT), and 44TSJ Collet Handpieces:

To insert or change accessories: insert pin provided into the pilot hole and through the spindle hole (turn spindle to align holes). Loosen chuck nut slightly with wrench provided. Insert shank of accessory into collet. Tighten chuck nut with wrench, keeping pin in pilot hole. Test for a secure hold by pulling on accessory. **Remove pin.**

Chuck Type – 30®, 30SJ, and (30H) Handpieces:

These handpieces have a geared 3-jaw #0 chuck. Open chuck jaws as far as necessary with key provided. Insert shank of accessory fully into the chuck. Tighten jaws with chuck key until accessory is secure and centered. If accessory does not run true, reopen jaws, rotate accessory and retighten. To release accessory, simply reopen chuck jaws with key and pull out accessory.



Hammer Type – 15, 15D, & 15SJ Handpieces:

These handpieces have a threaded spindle. Thread anvil or stylus into threaded spindle as far as it will go with clockwise motion. Insert pin provided into cross hole in anvil or stylus. Tighten and remove pin. To release accessory, insert pin into the cross hole and unthread.

Quick Change Type – 10, 10D, 18, 18D, 18SJ, 20, 20D, 20SJ, 52, 52D, and 52SJ Handpieces:

Keep an accessory in these handpieces at all times, during both operation and storage, or damage to the collet and handpiece may result. These handpieces accept only 2.35mm (3/32") shank accessories.

10 and 10D Handpieces:

To insert bur, turn lever 180° clockwise towards the back (shaft connection end) of handpiece. Insert or change a 2.35mm (3/32") shank bur and turn lever 180° forward counterclockwise. Make sure lever is completely locked into the forward position. **Never change burs while handpiece is running.**

18, 18D, and 18SJ Handpieces:

These handpieces have a lever on the side of the handpiece. Push the spring loaded lever down to open the collet and release the shank of accessory (2.35mm or 3/32" only). Insert accessory with the lever held down. **Never push lever down while handpiece or flex shaft are rotating.**



To minimize repetition, we sometimes drop prefixes associated with Freedom part numbers. Officially, Motors begin with M. (M.SR), Handpieces with H. (H.30[®]), and Speed Controls with C. (C.FCT).

Attaching Accessories to Handpieces

Quick Change Type — continued

20, 20D, 20SJ Handpiece:

This handpiece has a lever action collet release mechanism. Wait for the motor, flexible shaft, and accessory to come to a complete stop before turning the lever to open the collet and remove or insert accessory (2.35mm or 3/32" only). Turn lever 90° to left or right to open collet and change an accessory. To close the collet turn the lever back to the position parallel to the handpiece.



52, 52D, and 52SJ Handpieces:

These quick change handpieces have a unique push/pull collet release mechanism for rapid accessory changing (2.35mm or 3/32" only).

Wait for the motor, flexible shaft, and accessory to come to a full stop before opening the collet. After accessory has stopped rotating, pull the top grip forward with one hand while holding the bottom of the handpiece with the other. Remove the accessory and insert the shank of the new one fully into the collet. Push the top and bottom portions together.

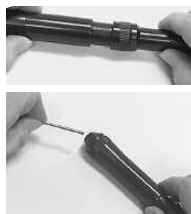

Chisel Type — 50 and 50C Handpieces (50C includes set of six chisels):

Inserting a chisel into this reciprocating handpiece should be done while the motor is in the "off" position, or with the handpiece disconnected. Loosen the locking nut with the 12mm spanner wrench provided by unscrewing it counterclockwise. Insert the tang fully into the plunger shaft. Tighten the locking nut clockwise until tool is held securely. **Do not over tighten.**



Handpiece Lubrication

(See page 8 for handpiece photos.)

8, 18, 20, 25, (25H), 28, (28H), 30[®], (30H) 35, 43T, 44T, (44HT) and 52:

These handpieces have been permanently lubricated. Their greased-shielded ball bearings **should absolutely not be lubricated.** (Handpieces listed in brackets are for use with Series TXH and LXH models only.)

10 and 10D: Lubrication should not be required for the first 2–3 months of continuous use. Then, approximately every two weeks of use, lubrication of the front and back ends of the handpiece is required. Follow the detailed instructions that come with your handpiece.

8D, 10D, 15D, 18D, 20D, and 52D Handpieces with Duplex Spring Connections:

Approximately **every 20 hours of operation apply 1 or 2 drops of Freedom oil** (Part No. MS10005) into the hole in the duplex spring collar next to the sheath connector. This will provide sufficient lubrication for both the duplex spring connection and the handpiece spindle.

15 and 15D: Clean off any dirt to prevent foreign matter from falling inside the handpiece. Put two drops of Freedom oil into the oil hole in the side of the housing. Run the handpiece slowly to distribute the oil. **Lubricate every 100 hours of use.**

50 and 50C: **After every 200 hours of use** you should clean and lubricate this handpiece. The old grease must be cleaned off of the interior cam chamber and replaced with new lubricant (Part No. MS10008). Follow the detailed instructions that come with your chisel handpiece.

Visit www.freedom.net

How-To Videos on Freedom flex shaft set-up, maintenance and operation!

General Accessory Recommendations

Foredom's wide assortment of rotary accessories makes your flexible shaft power tool very versatile. Use it for grinding, sanding, carving, engraving, brushing, cutting, buffing, and polishing on virtually any material. The Foredom Accessory Catalog offers the right accessories for your specific applications. Accessories may be purchased from your local dealer or directly from Foredom.

Always let the speed of the power tool do the work.

Avoid forcing the tool or applying too much pressure.

Experience will help you choose the right speed for the work you are doing. It's always a good idea to practice on a scrap piece of the same material you plan to use to determine the best accessories and speeds.

Always follow the manufacturer's RPM or speed recommendations when selecting accessories.

Your motor is supplied with a variable speed control that allows you to operate it at the most suitable speed for each job. The motor has a maximum speed rating of 18,000 RPM.

Always use an accessory which has the same or a higher speed rating than your tool. Using an accessory with a lower speed rating can result in serious injury.

Rotary Accessories and Motor Rotation: Running the motor in forward and reverse can help to extend the life of mounted abrasive points, Typhoon® burs, buffs, and brushes.

Use only the forward motor direction for fluted burs and cutters. Most will cut efficiently only when turning in this direction.

Abrasive Points, Wheels, and Discs

Use **Aluminum Oxide** (red color) for fast cutting on high-tensile, tough materials such as steel and malleable iron. Also use on glass and porcelain, etc.

Aluminum Oxide (white color) points have an extremely fine grit for producing a fine, high finish on high-tensile materials including stainless steel and glass. **Rubber Bonded Abrasive Wheels** are used for removing rust and for polishing with various grits. For best results, use finer grits for finishing at high speeds and coarser grits for stock removal at lower speeds. **Abrasive Discs** are for grinding, smoothing, and cleaning glass, high speed steel, and other tough materials.

Ruby Carvers have ruby crystals firmly bonded to a metal frame. These long lasting abrasives provide a smooth finish on hard materials such as steel, porcelain, glass, acrylic, soft and precious metals and wood.

Unique CeramCut Blue Stones are made from a mixture of special man-made ceramic grain and aluminum oxide bonded together. The ceramic provides a faster cutting action and is more durable so burs hold their shape longer than standard abrasives. They are ideal for use on any hard metal such as steel, stainless steel, chrome cobalt, platinum and titanium, as well as on wood.

Unique VStones have extra hard and long lasting vitrified aluminum oxide and ceramic grain with a special glass bead binder that makes them extremely long lasting, cool running and very aggressive — 40 to 60 grit. They work on the same materials as CeramCut Blue Stones, but much more aggressively.

Unique Scotch-Brite™ Radial Bristle Discs from 3M have thin flexible plastic bristles that get into hard to reach areas on flat and curved surfaces. Use on metal, acrylic, plaster, ceramics and wood without the need for compounds. These long lasting abrasives come in many size diameters and grits.

Unique CW Ceramic Impregnated Polishing Wheels are used for smoothing and polishing precious metals including platinum, gold, and silver. They also work on titanium, chrome cobalt, and all hard alloys. Wheels are 7/8" in diameter and come in six grits.

Burs and Cutters

Vanadium Steel Cutters are suitable for all materials except hardened steel and glass. They are used for cutting grooves and countersinking in soft materials, carving and hollowing woods, slotting and grooving woods, plastics, etc. **Steel Cutters** are good for shaping, grooving, slotting and cutting in wood, plastic and soft metals. Use **Carbide Burs** on wood, plastic and tough alloys. Carbide is generally referred to as the "hardest man-made metal".

High Speed Fluted Burs are used for fine detailed work on metal and other hard materials. Generally use medium speeds for stock removal and higher speeds for finishing work and when using smaller points. **Cut-Off Wheels** are used to cut off, groove, and trim metal, wood and ceramics.

Unique Typhoon® Carbide Burs provide very fast and aggressive material removal. Made for use on soft and hard woods, diestone, and plastics (do not use Typhoon burs on metal). They have aligned teeth that leave a smoother finish than other types of non-fluted tungsten carbide burs.

Drills

Step Drills are used to drill wood, precious metals, mild steel, bone, and mother of pearl. **Diamond Coated Twist Drills**, made of wire gauge steel with diamond coating, are used to drill extremely fine holes in stone, ceramics, tile, glass, and hard metals.

Plated and Sintered Diamond Points and Discs

are used to remove stock from extremely hard materials such as tungsten and tantalum carbide cutting tools, dies and molds, broaches, and for grinding and pre-polishing synthetic jewels and precious metals, fiberglass, reinforced plastics, PVC and ceramics. Sintered diamonds last far longer than plated diamonds and can be re-sharpened as desired with a wet dressing stone to expose new diamond particles.

Sanding Drums, Bands, and Discs

These are used for removing rust, smoothing rough surfaces and for sanding jobs on wood, plastic and metal. (Avoid using too much pressure which will cause clogging or a build-up on the work surface.) For best results, use medium speeds for coarser grits and larger diameters. Use higher speeds for finishing work or with smaller sizes. **Unique 3M Ceramic Purple Coated Abrasive Bands and Discs** contain patented Cubitron™ ceramic aluminum oxide mineral that sharpens itself with use. They last 2 to 4 times longer than traditional aluminum oxide discs and remove material faster with less heat and loading.

Cotton or Felt Bobs and Buffs

Solid Felt Buffs or Bobs are used in combination with gritty or smooth compounds for a variety of buffing and polishing operations on plastic, wood, and metal. They vary in shape and come in three hardnesses — medium, hard, and rock hard.

Loosely-stitched Soft Cotton Buffs are used for delicate work on precious metal and during polishing operations. Generally use high speeds for cutting down and buffing. Medium speeds are used for more delicate, precise work and for polishing.

Brushes

Miniature Power Brushes are generally used on metal surfaces and hard-to-reach areas. They are ideal for deburring, surface finishing, edge blending, roughening to create a good bonding surface, and general cleaning. Use high speeds for cleaning and deburring. Medium speeds are needed when cleaning hard-to-reach areas and edge blending.

Unique Scotch-Brite™ Radial Bristle Discs from 3M have thin flexible bristles that get into hard to reach areas on flat and curved surfaces. Use on metal, acrylic, plaster, ceramics and wood without the need for compounds. They can sand, smooth, polish, or burnish metal, plastic, or wood to a bright finish.

Compounds

Foredom has seven different compounds. In addition to Emery, Tripoli, and Red and White Rouges, there is **unique Platinum Blue** for pre-polishing and cutting down platinum and other metals, and for final polishing **unique Platinum White** (8000 grit) that produces a deep luster on platinum, other metals, and acrylics. **Carnauba** is the hardest wax available. It produces a high luster on wood and painted surfaces.

2" Wheels and Discs for Angle Grinder Attachment

Foredom recently introduced several types of wheels with 3/8" arbor holes for grinding, deburring, shaping, and cutting on various materials. Also new are various types of psa backed abrasive discs, screens and velcro heads for sanding on wood, metal, plastic, glass, stone and more.

Introduced in 2010, Foredom's Angle Grinder Attachment is designed for use on the H.30®, H.30H, or H.30SJ Chuck-Style Handpieces. It is excellent for a broad range of sanding, polishing and finishing work with 2" and smaller discs and 3/8" arbor hole wheels.

Bur and Tool Holders

Foredom has three rotating bur holders and two small holders with covers. Two of the rotating models have center cups for holding small tools such as files and screwdrivers. A bur holder is the perfect companion product for your collection of burs, drill bits, and other accessories of various size shanks.

The Foredom Accessory Catalog features the right accessories for your specific applications. Accessories may be purchased from your local dealer or directly from Foredom. Contact:

The Foredom Electric Company,
16 Stony Hill Road, Bethel, CT 06801
Phone: (203)792-8622 • Fax: (203)796-7861

Visit our online store at www.foredom.net.

Maintenance Procedures

Always make sure your power tool is unplugged during maintenance procedures!

It is very important to routinely clean your Foredom® Power Tool and lubricate the shaft (NOT the motor), especially in areas that generate a lot of dust.

Dirt and improper lubrication are the most common causes of poor operation and excessive wear.

Always disconnect power tool before cleaning or servicing.

Note: The motor has permanently lubricated ball bearings and does not require additional lubrication.

Routine Cleaning of Motors

Foredom Motors need air circulation through the motor housing to remove waste heat and cool the windings. Inlet and outlet slots



provide the means for air flow. However, saw dust and conductive debris (like metal filings or gold dust) can enter in through these slots. If not cleaned regularly, dust can collect, making a bridge between parts, causing an electrical short.

In high dust environments, Foredom recommends cleaning the motor every 40 hours of use.

To remove dirt and dust buildup, motor brushes should be removed, cleaned and replaced, and air should be blown through the motor.

Routine Cleaning and Lubrication of Flexible Inner Shaft

The shaft should be checked, wiped clean, and relubricated with grease every 50 hours of use. With every 200 hours of use, the shaft should be thoroughly cleaned with solvent and lubricated. Use Foredom flex shaft grease (p/n MS10006) or high quality white lubricating grease.

Be sure to watch shaft and sheath maintenance videos on www.foredom.net

Exposing the Inner Shaft

1. Remove handpiece (see page 5).
2. Loosen set screw on motor connector.
3. Slide outer sheath out of motor connector and wipe shaft clean.



4. Apply a very light coating of lubrication to shaft starting at the top and working downward to



about one inch from the handpiece end. Apply grease with your finger tip or small brush. Don't overdo, apply a light film of grease. Once the machine is running, the shaft itself will spread the grease. If too much grease is applied, the excess will work its way into the handpiece and eventually seep out between the handpiece and sheath. For this reason, apply a bit less near the handpiece end of the shaft.

Never operate the motor with the outer sheath removed from the flexible shaft.

5. Replace and adjust sheath so that shaft key tip extends 3/4" (19mm) from sheath. Retighten the set screw in motor connector. See page 5, No. 2.
6. Clean outside of sheath by wiping with a cloth.
7. Hang motor over a trash can and run it for about 10 minutes before attaching the handpiece. This provides enough time for the grease to warm up, spread and drain off. Wipe off any excess grease at tip end of sheath.



8. Re-attach handpiece. See page 5.

Always make sure your power tool is unplugged when conducting maintenance procedures!

Replacement of Worn Shafts and Sheaths

Shafts and sheaths last longer when they are not used at sharp angles or loops, since wear occurs at the points of greatest friction. There is no way to avoid ultimate wear, and under normal conditions a flexible shaft machine may require several replacement shafts and sheaths during its lifetime.

To expose the inner shaft follow steps 1, 2, and 3 on the previous page.

Next, remove motor connector with 1" open end or adjustable wrench.

Motor connector has a left hand thread and must be turned clockwise (right) for removal.

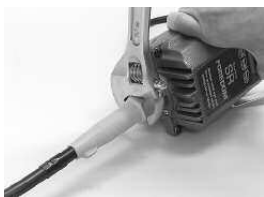

Loosen set screw on the flexible shaft motor coupling and slide shaft off the motor shaft.

Installation of New Shaft

1. After removing old shaft, loosen set screw on the new flexible shaft motor coupling and slide coupling onto motor shaft.

2. Tighten set screw securely onto the flat of the motor shaft.

3. Grease shaft prior to putting on the sheath. (See lubrication instructions on page 13.)

4. Slide motor connector back up over the shaft and tighten to the left (counterclockwise).

5. Slide sheath over flexible shaft with plain fitting directed toward the motor and into the motor connector. (Each end of the sheath has a metal fitting. One is plain, the other has a groove around it to fit the handpiece.)

6. Adjust the shaft (page 5 and top right) and tighten sheath set screw in motor connector.

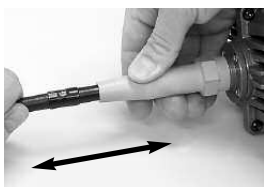
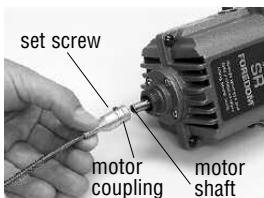

Visit www.foredom.net

How-To Videos on Foredom flex shaft set-up, maintenance and operation!

Shaft and Sheath Adjustment



Place the entire unit on a flat surface with shaft and sheath extended straight.

Adjust the exposed tip of the flexible shaft at the handpiece end so that it extends 3/4" (19mm) beyond the sheath.

This is done by moving the sheath in or out of the motor connector. When the correct adjustment is made, tighten the screw in the motor connector.

Replacement of Motor Brushes



Motor brushes should be checked for wear periodically. When new they are approximately 3/4" (19mm) long. Replace them when they have worn to 1/4" (6mm). To remove brushes, disconnect motor power cord and unscrew the brush caps. Remove the worn motor brushes, replace with new motor brushes, and screw motor brush caps back on. Be sure to replace both motor brushes even if one of them is less worn than the other.

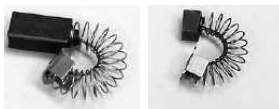

New Motor Brush

Motor Brush that needs replacement

Recommended Spare Parts & Supplies

For 1/6 hp Series SR, SRB and SRM (115v & 230v)

- **MSMK-10 Maintenance Kit** which contains:
Flexible shaft (S-93)
Pair of motor brushes (MP132P)
Foredom flexible shaft grease (MS10006)
Owner's Manual

Individual Parts

- Pair of motor brushes (MP132P)
- Flexible shaft (S-93)
- Outer sheath (S-77)
- Neoprene sheath (S-77N)
- Foredom flexible shaft grease (MS10006)
- Motor Connector (UA111P)

Repair Services

Authorized repair service is available at the Foredom factory in Bethel, CT. Send items for repair to the factory marked:

“Attention: Repair Department”

The Foredom Electric Company

16 Stony Hill Road, Bethel, CT 06801

Enclose the item(s), a packing list, and information regarding the problem or repairs required. Estimates of repair cost will be made upon request.

If the cost (labor plus parts) is more than fifty percent of the price for a new replacement we will contact you and recommend a trade-in offer.

Storage

Store your Foredom power tools in a DRY, clean, dust-free area, and out of the reach of children.

Visit www.foredom.net

How-To Videos on Foredom flex shaft set-up, maintenance and operation!

Motor Hangers

Foredom motor hangers have bases that can be screwed or clamped to a bench. They keep hang-up motors at just the right distance for optimal use. Safety clips at the top prevent the motor from jumping or twisting off at start up and during use. Motors that slip off an open hook can cause serious injury.



Motor Hanger MAMH-1

can hang either one or two motors. It comes with **MABC-1 Clamp** that clamps onto a workbench & **MAHR-2** Handpiece Rest.

Motor Hanger MAMH-2

can hang either one or two motors. It comes with **MABC-2 Base** that screws into a workbench and **MAHR-2** Handpiece Rest.

Please retain your proof of purchase for warranty repairs.

LIMITED WARRANTY

Series SR and SRH Flexible Shaft Power Tools

Foredom warrants the Series SR and SRH Motors to be free of defects in material or workmanship for a period of 2 years after purchase. During the warranty period, the defective product will be repaired or replaced without charge or, at our option, the purchase price will be refunded. This warranty does not cover damage caused in transit or by accident, misuse, or ordinary wear of shafts, sheaths, bearings, armature, and motor brushes.

ALL IMPLIED WARRANTIES, INCLUDING BUT NOT LIMITED TO WARRANTIES OF FITNESS AND MERCHANTABILITY, ARE HEREBY LIMITED IN DURATION TO A PERIOD ENDING 2 YEARS FROM DATE OF PURCHASE, AND WE WILL NOT BE LIABLE OR RESPONSIBLE FOR ANY SPECIAL OR CONSEQUENTIAL DAMAGES.

Repair or replacement will be made at our option if the product is returned post-paid to:

**The Foredom Electric Company
16 Stony Hill Road
Bethel, CT 06801**

All warranty repairs must be done at the factory at the above address. We will not pay any shipping or transportation charges. Handpieces have a 90 day warranty. Shafts, sheaths and duplex springs are not covered by this warranty since they are especially sensitive to the pressure and stress variables of the individual operator. This warranty only covers the original purchaser of the product. Some states do not allow limitations on how long an implied warranty lasts or the exclusion or limitation of incidental or consequential damages so the above limitations may not apply to you. This warranty gives you specific legal rights, and you may also have other rights which vary from state to state.

Contact Information

If you have a warranty issue with your Foredom power tool please use the contact information below. For more information on Foredom machines, handpieces or accessories, contact your local dealer. When no local dealer is available contact Foredom at:

The Foredom Electric Company, 16 Stony Hill Road, Bethel, CT 06801

Tel.: (203) 792-8622 • Fax: (203) 796-7861

Email: customerservice@blackstoneind.com

www.foredom.net