

Parts List

TX Motor Series 115v and 230v

NOTE:

The Brush Tube Assemblies (18) are fastened to the inside of the End Bell Housing(14) with: Apollo 2240 cyanoacrylate adhesive and Loctite Tak Pak 7452 Accelerator or equivalent.

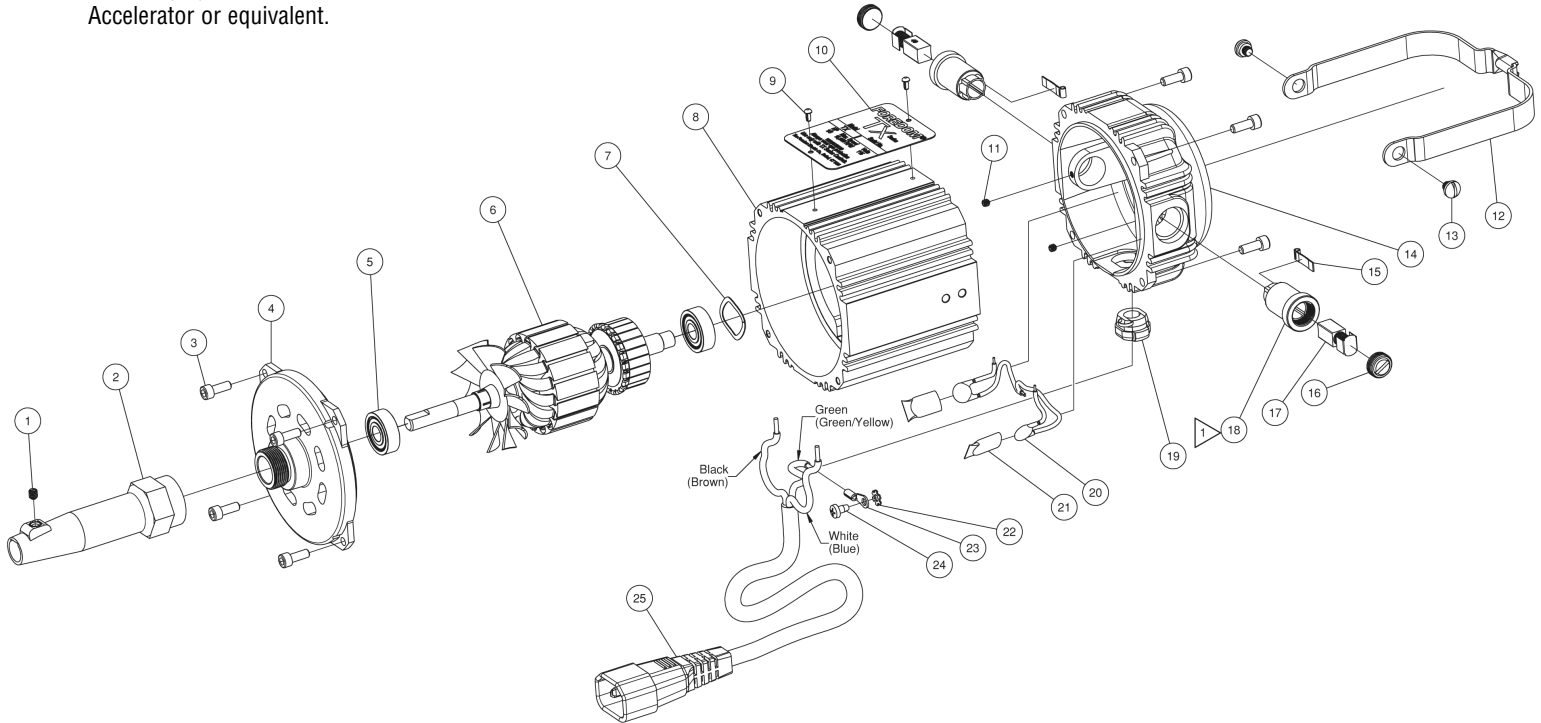

Motor Series	Motor Part No.	Armature Assembly Part No. (Includes 2 Ball Bearings)	Specification Nameplate Part No.
TX 115V	MP90-939	MP439	UA10384-TX
TX 230V	MP90-943	MP443	UA10384-TX2

Item	Part No.	Description	Qty
1	UA113	Set Screw, 8/32 x 3/16, Slotted Headless, Cup Point	1
2	UA111P	Motor Connector	1
3		Cap Screw 8/32 x 7/16", Hexagon Socket Head Cap Screw	8
4		End Plate	1
5	HP61	Ball Bearing, Ø22mm x Ø8mm x 7mm	1
6	See Table	Armature Assembly (Includes 2 Ball Bearings)	1
7		Wavy Spring Washer, Ø22mm x Ø17 x 3mm 0.3mm Thick	1
8		Center Housing	1
9	UA577	Grooved Stud, Ø.086 x .187	2
10	See Table	Nameplate	1
11		Set Screw, 6/32 UNC x 1/8, Hexagon Socket, Cup Point	2
12	UA1059	Motor Hanger	1
13	UA106	Motor Hanger Screw	2
14		End Bell Housing	1
15		Terminal, Brush	2
16	MP120	Cap, Brush Tube	2
17	MP319P	Brush, Motor (Pair)	1
18		Brush Tube	1
19		Strain Relief, Cordset	1
20		Capacitor, Type 25 U, 220 pf, 3KV	2
21		Insulation Cover, Capacitor	2
22		Lock Washer, #6, External Tooth	1
23		Ring Terminal, #6	1
24		Self Tapping Screw, 6/32 x 1/4, Cross Recessed Pan Head	1
25	CP10829	Cordset	1

FOREDOM®

The Freedom Electric Company

16 Stony Hill Rd., Bethel, CT 06801 • 203-792-8622

Fax: 203-796-7861 • www.freedom.net

Email: customerservice@blackstoneind.com